

# LED 5W Hi Lumen Retrofit Series

Stock No.	Product Description
LED-1421	CFLA-120-5-80-SW (Soft White)
LED-1422	CFLA-120-5-80-DL (Daylight)

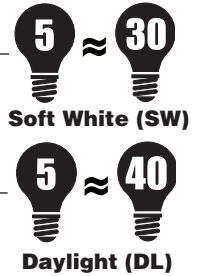

**Description:**

Fully encapsulated, 120 Volt, 5 Watt, E26 medium base mounting that integrates energy saving LED technology into a standard A19 or CFL format. Available in Soft White (SW) or Daylight (DL).

- 5 Watt, 120 Volt operation  
Remote transformer not required  
Operates off of standard house current
- Soft White 230 lumens SW (3000K)
- Daylight 280 lumens DL (5400K)
- Compare to 30W (SW) or 40W (DL) light output
- 80 on board LED diodes
- Up to 50,000 hour lamp life
- Very low heat output
- Not dimmable
- 2 year warranty

**Applications:**

The 5W CFLA lamp has been designed to retrofit existing incandescent and/or CFL installations, thereby reducing maintenance and energy expenditures - and as an energy saving light source for new fixtures and installations.

- Task lighting
- Hospitality lighting
- Recessed downlighting
- Residential lighting

**Packaging:**

Master pack: 50 each

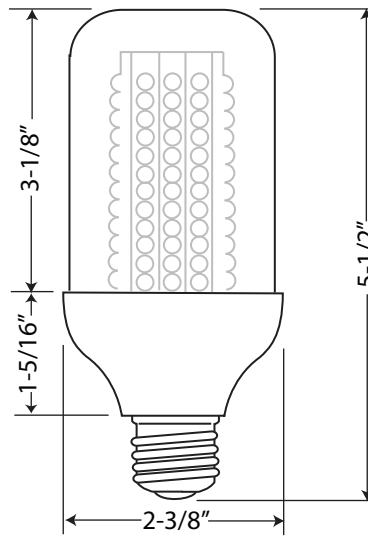

**Technical Specifications:**

Bulb Type:	Standard	Base Type:	Medium E26
Bulb Material:	Plastic	Replaces:	30W - 40W
Lumens:	230SW / 280DL	Life Time:	Up to 50,000 Hrs.
Input Voltage:	120V	Output Power:	5W
Dimensions:	2-3/8" x 5-1/2"	Beam Angle:	175°
Light Source:	80pc LED	Color:	(SW) est. 3000K (DL) est. 5400K
Dimmable:	No	Lumens / Watt:	55
CRI:	65	Inert Gases:	No
UV / IR Radiation:	No		

Note: All specification information falls within a ± 2% range

**JOIN THE RETROFIT REVOLUTION™**



**Light Emitting Designs**  
Environmental Lighting Solutions  
a division of TADD, LLC

NOTE: Light Emitting Designs is providing this information to the general public. Please note that all products contained herein are trademarked, copyrighted, and/or have patents pending. Any use of these designs is strictly prohibited without prior written consent. Light Emitting Designs protects its proprietary information vigorously in the courts of the United States of America.

108 S. Wynstone Park Drive • Suite 103 • N. Barrington, IL 60010 • (847) 380-3540  
FAX: (847) 380-3542 www.led-llc.com Specs subject to change without notice. 020110\_LED1421